

VOLVO PENTA INDUSTRIAL DIESEL

TAD650VE

147 kW (200 hp) crankshaft power acc. to ISO 3046

The TAD650VE is a powerful, reliable and economical Industrial Diesel Engine built on the dependable Volvo in-line six design.

Durability & low noise

Designed for the easiest, fastest and most economical installation. Well-balanced to produce smooth and vibration-free operation with low noise level, featured with high torque.

To maintain a controlled working temperature in cylinders and combustion chambers, the engine is equipped with piston cooling. The engine is also fitted with replaceable valve seats/guides to ensure maximum durability and service life of the engine.

Operational economy and Low exhaust emission

The common rail injection and air charging system with low internal losses contributes to excellent combustion and low fuel consumption.

The TAD650VE complies with EPA/CARB Tier 3 and EU stage III exhaust emission regulations. These regulations are met by using V-ACT™ (Volvo Advanced Combustion technology).

V-ACT includes a flexible high pressure fuel injection system, an air management system and an enhanced electronic controller.

Easy service & maintenance

Easily accessible service and maintenance points contribute to the ease of service of the engine.

Technical description:

Engine and block

- Optimized cast iron cylinder block with optimum distribution of forces
- Piston cooling for low thermal load on pistons and reduced ring temperature
- Drop forged steel connecting rods
- Crankshaft induction hardened bearing surfaces and fillets with seven bearings for moderate load on main and high-end bearings
- Keystone top compression rings for long service life
- Viscous type crankshaft vibration damper to withstand torsional vibrations
- Replaceable valve guides/seats
- Three PTO positions at flywheel end



Features

- High torque at low revolutions and fast response
- Withstands high sulphur fuels
- Fully electronic with Volvo Penta EMS II, both CAN-bus & Stand Alone Interface (optional)
- High power density
- EPA Tier III / EU stage III emission compliant
- Same footprint as stage 2

- Lift Eyelets
- Flywheel for flexible coupling and friction clutch
- Transport brackets
- Pulley for AC compressor
- Efficient and reliable waste-gate turbo charger

Lubrication system

- Full flow integrated oil cooler, side mounted
- Full flow disposable spin-on oil filter, for extra high filtration
- Rotary displacement lubricating oil pump, gear driven by the crankshaft
- Deep centre oil sump

Fuel system

- Non-return fuel valve
- Fuel pre-filter with water separator and water-in-fuel indicator / alarm. Integrated hand-pump.
- Belt driven low-pressure fuel pump
- Common rail fuel injection system

Cooling system

- Air to air intercooling

- Belt driven, maintenance-free coolant pump with high degree of efficiency
- Efficient cooling with accurate coolant control through a water distribution duct in the cylinder block
- Reliable thermostat with minimum pressure drop
- Fan hub

Electrical system

- Engine Management System 2 (EMS 2), an electronically controlled processing system which optimizes engine performance. It also includes advanced facilities for diagnostics and fault tracing.
- The instruments and controls connects to the engine via the CAN SAE J1939 interface, either through the Control Interface Unit (CIU) or the Digital Control Unit (DCU).
- Sensors for oil pressure, oil temp, boost pressure, boost temp, coolant temp, water in fuel, fuel pressure and two speed sensors.
- Alternator 24V/80A
- Starter motor 5.5kW

**VOLVO
PENTA**

TAD650VE

Standard and Optional equipment

Engine

- Automatic belt tensioner •
- Lift eyelets •
- Flywheel housing with conn. acc. to SAE 2 •
- Flywheel for clutch SAE 10" and 11.5" •
- Flywheel for ZF, DANA and Allison –
- SAE 3 flywheel housing –
- Vibration dampers •

Engine suspension

- Front engine brackets •
- Flexible engine mounting –

Lubrication system

- Central oil sump Sheet metal, 30° all directions •
- Oil sump, deep in front –
- Short oil dipstick, in front •
- Flexible dipstick –
- Oil filling on top •

Fuel system

- Fuel prefilter with integrated hand pump and water in fuel indicator •

Intake and exhaust system

- Closed crankcase ventilation –
- Turbocharger, high, Exhaust towards flywheel, air inlet elbow •

Cooling system

- Fan Ø 600, 660 and 700 mm –
- Fan hub 63 mm •
- Alternative fan positions –

Control system

- Engine Management System 2 (EMS 2) with CAN-bus interface SAE J1939 •
- CIU, Control Interface Unit –
- DCU, Digital Control Unit –

Electrical system

- Alternator 24V / 80A •
- Starter motor, 24V / 5.5kW •
- Connector for extra starter motor –
- 24V glow plugs with power relay •

Miscellaneous

- Hydraulic Pump –
- Coolant pre-heater –
- Crankshaft pulley –
- Air compressor –

Engine Packing

- Preservation / Packing / Standard •

– optional equipment or not applicable,

• included in standard specification

Technical Data

General

Engine designation	TAD650VE
Number of cylinders	in-line 6
Method of operation	4-stroke
Bore, mm (in.)	101 (3.98)
Stroke, mm (in.)	126 (4.96)
Displacement, l (in ³)	6.0 (370)
Compression ratio	18.4:1
Dry weight, kg (lb)	565 (1246)
Wet weight, kg (lb)	585 (1290)

Performance

IFN Power, without fan at 2300 rpm, kW (hp)	147 (200)
Torque, standard at 1600 rpm, Nm (lbf ft)	750 (553)

Lubrication system

Oil system capacity incl filters, liters (US gal)	16(4.23)
---	----------

For details see Technical data

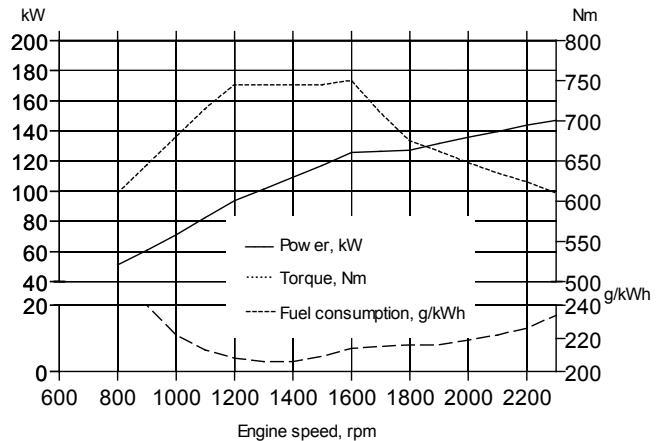

Dimensions TAD650VE

Not for installation

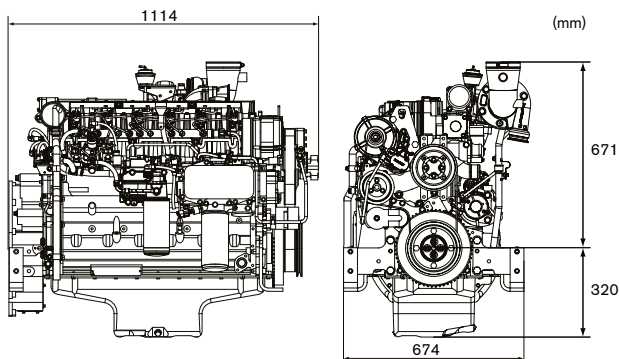

Note! Not all models, standard equipment and accessories are available in all countries. All specifications are subject to change without notice. The engine illustrated may not be entirely identical to production standard engines.

Power Standards

The engine performance corresponds to ISO 3046, BS 5514 and DIN 6271. The technical data applies to an engine without cooling fan and operating on a fuel with calorific value of 42.7 MJ/kg (18360 BTU/lb) and a density of 0.84 kg/litre (7.01 lb/US gal, 8.42 lb/Imp gal), also where this involves a deviation from the standards.

Rating Guideline

IFN Power rating corresponds to ISO Overload Power. It is intended for applications where intermittent power is utilized less than 1 hour within any period of 12 hours of continuous operation. The average load factor must not exceed the continuous rating. ICFN Power rating corresponds to ISO Standard Power for continuous operation. It is intended for constant load applications with uninterrupted service at full load for extended periods of time.

VOLVO PENTA

AB Volvo Penta
SE-405 08 Göteborg, Sweden
www.volvopenta.com